

TANK GAUGING SYSTEMS

TGS SIDE MOUNTED SOUR SERVICE
MECHANICAL LEVEL GAUGE
TGS - 5010

www.tankgaugingsys.com

Grease Sealed Pulley System

Magnetic gauge board for simple "tank-in-service" installations (no welding required)

Unique float design - no need for guide wires

Large easy to read gauge board with reflective, long-life 3M decal

Complete gauge package supplied - no additional parts required

Accommodates most vessel shapes and sizes

Add CSA Class 1, Div. 1 Point Switch

Cost-effective gauging of Sour fluids

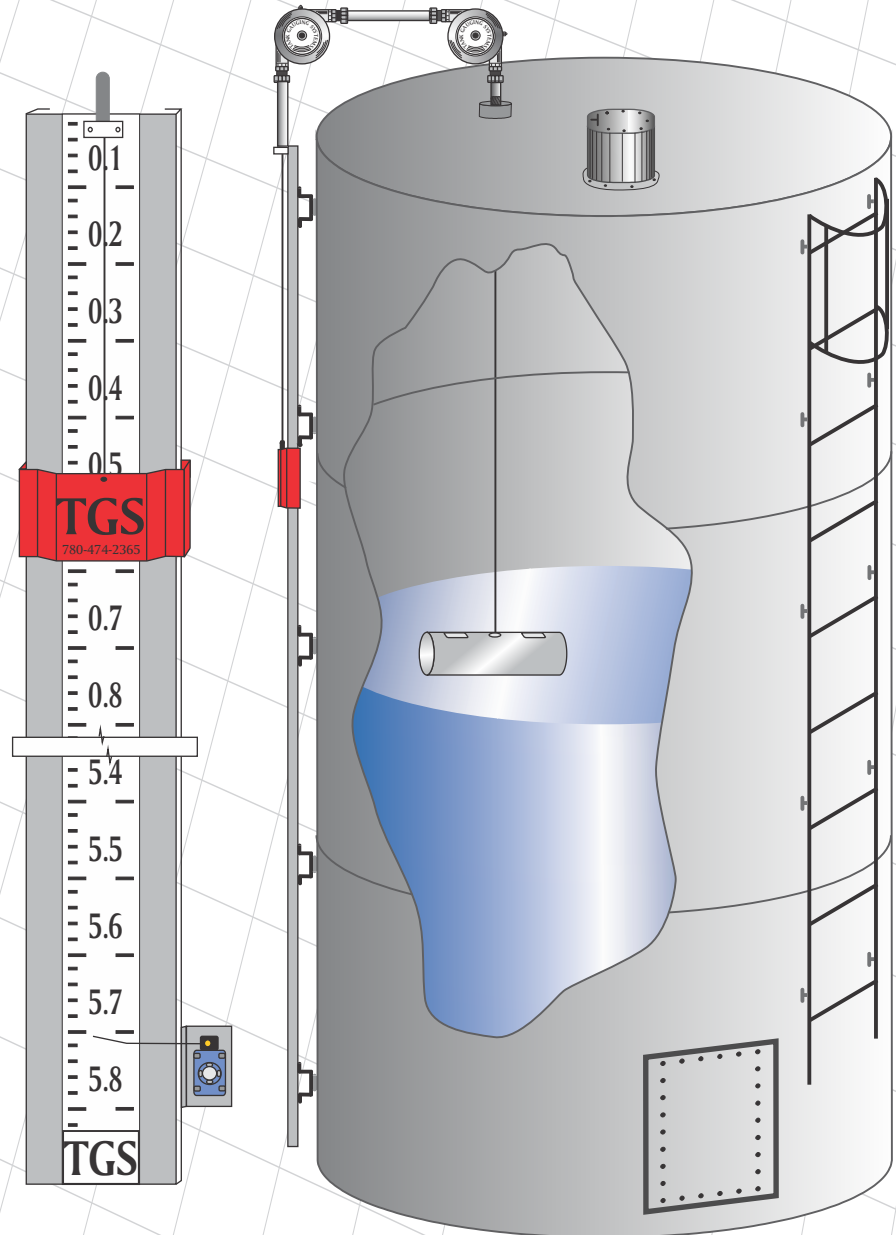

Head Office: 12532 - 124St. Edmonton, AB, T5L 0N5

Edmonton 780-474-2365

Calgary 403-685-8867

TANK GAUGING

TGS SIDE MOUNTED SOUR SERVICE
MECHANICAL LEVEL GAUGE
TGS - 5010

SYSTEMS

FEATURES

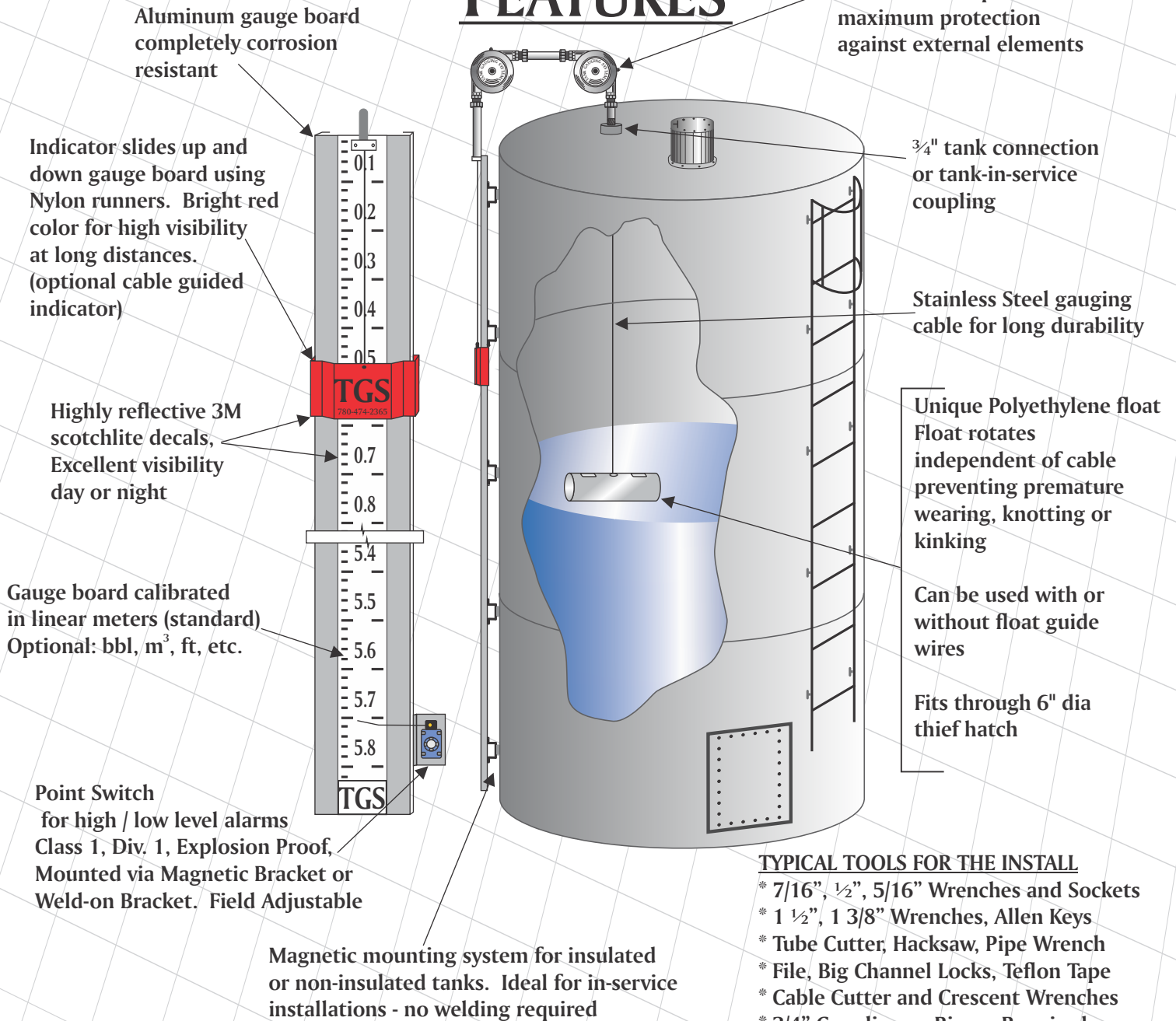

TYPICAL TOOLS FOR THE INSTALL

- * 7/16", 1/2", 5/16" Wrenches and Sockets
- * 1 1/2", 1 3/8" Wrenches, Allen Keys
- * Tube Cutter, Hacksaw, Pipe Wrench
- * File, Big Channel Locks, Teflon Tape
- * Cable Cutter and Crescent Wrenches
- * 3/4" Coupling or Bigger Required
- * Grease Gun & Grease if Required

Technical Specifications

Tank Gauging Systems, Edmonton - Calgary

Edmonton: 780-474-2365

Calgary: 403-685-8867

TANK GAUGING SYSTEMS

TGS SIDE MOUNTED SOUR SERVICE MECHANICAL LEVEL GAUGE TGS - 5010

ITEM	DESCRIPTION / MATERIAL
1.)	Sealed Pulley System • Grease filled, 3/4" tank coupling
2.)	Clamping Block • PVC
3.)	Gauge Board • 14 Gauge Aluminum - 6" wide
4.)	Decal • High reflective 3M decal, 4" width
5.)	Indicator/Slider • Aluminum slider with 3M decal
6.)	Polyethylene Float - standard • Fiberglass Upgrade • Stainless Steel Upgrade
7.)	1/8" Stainless Steel Cable Clamp
8.)	316 Stainless Steel Cable - 3/32" - 30ft Standard
9.)	3/4" Male NPT • Tank in service coupling also available
10.)	Magnetic Mounting Bracket
10a.)	Weld-on Mounting Bracket
11.)	High / Low Level Alarm Point Switch • CSA Class 1, Div. 1; Field adjustable
OPERATING	
• Temperature: 90°C (standard) 160°C max.	
• Pressure: 16oz (standard)	
• Measurement Range: Up to 42ft (higher available)	
** Typical Shipping Weight: 65lbs	

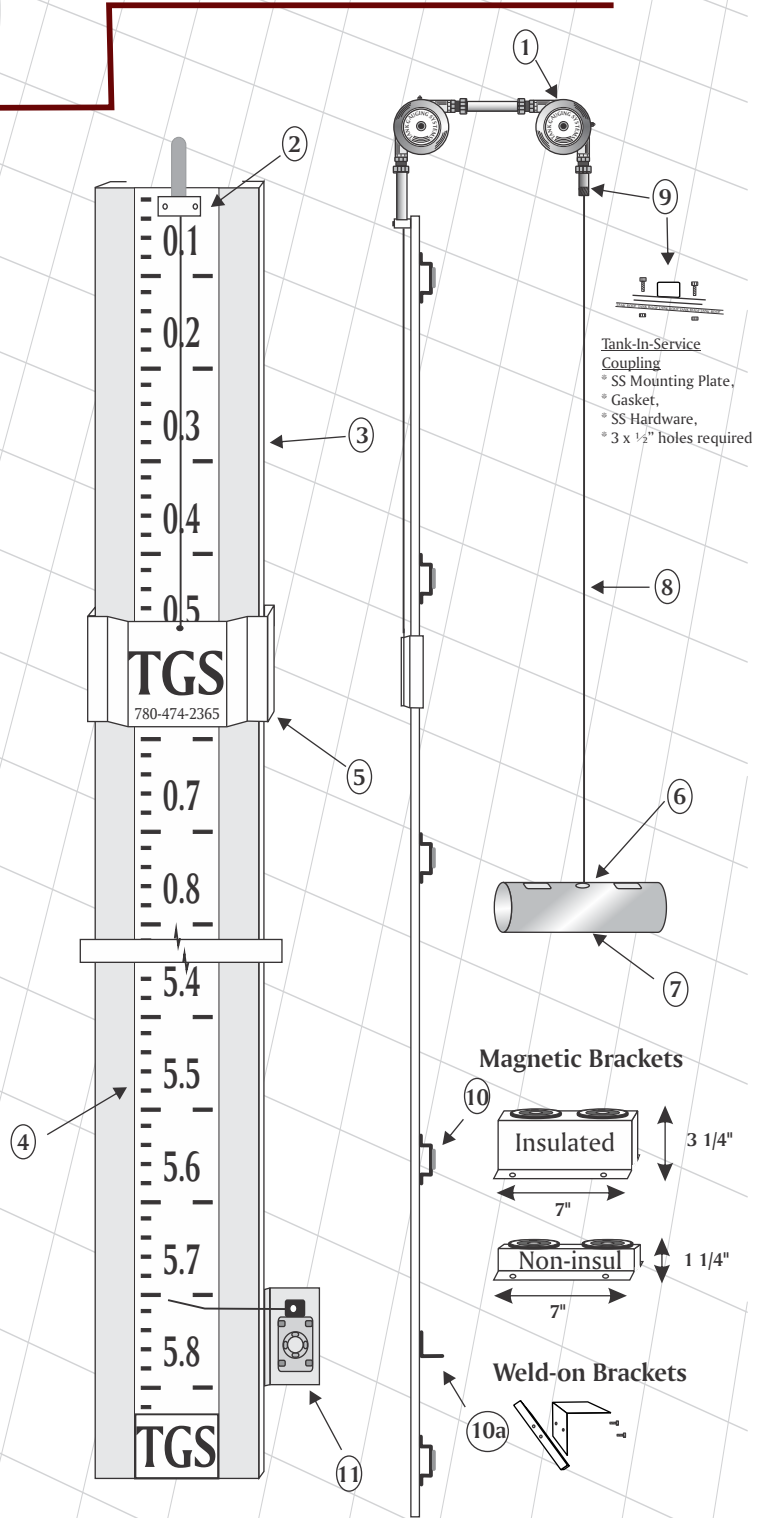

Technical Specifications

Tank Gauging Systems, Edmonton - Calgary

Edmonton: 780-474-2365
 Calgary: 403-685-8867

TANK GAUGING SYSTEMS

5010

TGS - 5010 Technical Order Guide

Model TGS 5010 provides local indication of tank fluid level using the highest quality mechanical components to insure long lasting, reliable fluid monitoring. Standard Gauging packages includes TGS's unique Fiberglass Float with Stainless Steel Swivel, Aluminum Gauge Board & Indicator, Decals manufactured from highly reflective 3M material, Enclosed Sealed Pulley's, 316 Stainless Steel Cable, Stainless Steel Cable Clamp, 3/4" Process Connection and TGS's unique friction fit Weld-on Mounting System or Magnetic Mounting Brackets.

ORDERING CODE: TGS 5010 - A / B / C / D / E / F / G .

CODE	TANK SIZE / HEIGHT (A)
X	Tank Height Example - 20ft

CODE	DECAL CALIBRATION (B)
M	Metric - 1cm Increments - Standard
C	Cubic Meters
BBL	Barrels
FT	Standard - Ft & Inch
X	Other - Specify

CODE	TANK CONNECTION (C)
3/4"	3/4" - Standard
X	Other - Specify

CODE	CABLE GUIDE (D)
20"	20" - Standard
X	Longer - Specify

CODE	OUTPUTS (E)
N	No Outputs
R	Relay - Add (B) or (M) for Bracket
P	Pneumatic - Add (B) or (M)
B	Bolt on Mounting Bracket
M	Magnetic Mounting Bracket

CODE	CABLE GUIDED FLOAT (F)
N	NO Cable Guides with Tensions
Y	Cable Guides with Tensioners
W or A	(W) Weld-on (A) Weighted Anchor

CODE	BRACKETS (G)
W	Weld-on Mounting Brackets
NIM	Magnetic Bracket Non-Insulated Tank
IM	Magnetic Bracket Insulated Tank

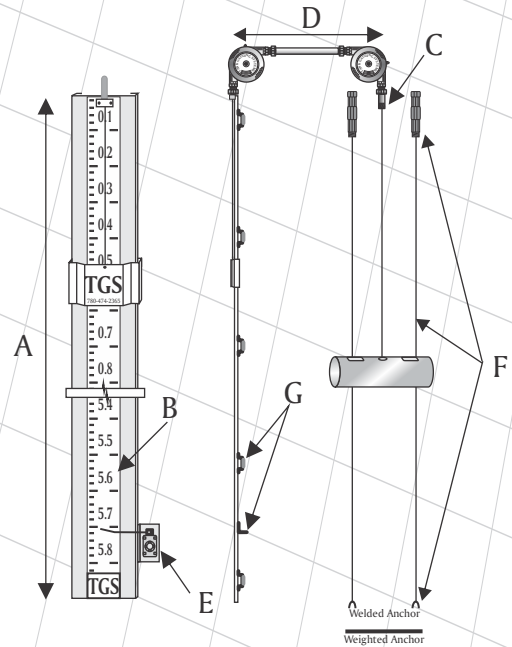

TANK SPECIFICATIONS:	
Tank Heated:	Yes/No
Temperature:	Ambient Other:
Fluid:	SG:

Customer Information

Company Name: _____ Contact Name: _____
 Phone Number: _____ Fax Number: _____
 Date Required: _____ PO / Ref Number: _____ Ship Via: _____
 Invoicing: _____
 Shipping: _____

Technical Specifications

Tank Gauging Systems, Edmonton - Calgary

Edmonton: 780-474-2365

Calgary: 403-685-8867

TANK GAUGING SYSTEMS CORP.

12532 124 Street, Edmonton, Alberta, T5L 0N5
Edmonton Ph: 780-474-2365
Calgary Ph: 403-685-8867

TGS 5010 SIDE MOUNTED SOUR SERVICE PULLEY INSTALLATION INSTRUCTIONS

- 1. Gauge Board:** The gauge board has been shipped in sections with a joiner at the end of each section. Assemble the gauge board together via the joiners and bolt magnetic or weld-on brackets to the gauge board. All the necessary hardware (washers, nuts and bolts) has been included in the gauge package.
- 2. Mounting the Gauge Board:** The gauge board will be mounted to the tank via Magnetic Mounting Brackets or Weld-on Mounting Brackets. The gauge has been designed to be installed and serviced while the tank is in-service. If possible always try to mount the gauge board so that the top of the gauge board is level with the roof of the tank (the point at which the roof begins to slope) and close to the thief hatch so the float can be reached through the thief hatch.
- 3. Drilling Holes:** Omit this step if a coupling is already installed in the tank. Position the $\frac{3}{4}$ " female threaded end of the Pulley System over the Clamping Block mounted at the top of the gauge board. A 2' length of $\frac{3}{4}$ " PVC tubing had been supplied and will connect the Pulley to the clamping block. Locate position on the tank to drill a hole. The hole can be drilled approximately an arms length from the thief hatch (1 1 $\frac{1}{2}$ ft from the hatch). Drill a hole big enough to insert the $\frac{3}{4}$ " nipple and file any rough edges that occur as a result of drilling. If drilling while tank is in-service use plenty of cutting oil and be careful.
- 4. Mounting Pulley Assembly:** Tighten the pulley with the $\frac{3}{4}$ " nipple into the tank. BE SURE THE SIDE OF THE PULLEY WITH THE GREASE NIPPLES ARE ATTACHED TO THE TANK. If using the tank in service coupling place the top half (O-ring, Washer and PVC) on the top of the tank and attach the bottom half of the coupling (O-ring, Washer, PVC and nut) from inside the tank. The PVC side of the pulleys will then attach to the clamping block mounted on the gauge board. If required an extension may be added between the pulley's to increase the length. Thread $\frac{3}{4}$ " pipe to the desired length OR if using compression fittings use 1" SS tubing and install between the pulley's. Whether adding or decreasing the length between the pulleys always leave the cable inside the pulley that is grease filled. (it has a grease nipple threaded into it) For best operation try to keep the pulleys as level as possible. Cut the end of the PVC tube after the pulley has been installed so that approximately 1" of PVC is through the clamping block on the gauge board.
- 5. Stainless Steel Gauging Cable:** Run the Stainless Steel gauging cable from the inside of the tank through the Pulleys (if not already done). Place the cable through the hole in the bolt on the slider and loosely tighten for now. Attach the float to the other end of the cable via the cable clip and/or the cable crimp supplied.
- 6. Calibration:** Gently lower float into the tank. Dip tank and adjust the slider/indicator to the appropriate level. Tighten nut on the slider. Be sure to add additional grease to the pulley head once the indicator has traveled the full scale of the gauge board a few times.

** If using float cable guide assembly, mounting connections are 18" center to center

